

- ◆ Compliant with SFF-8431, SFF-8432 and IEEE802.3ae
 - ◆ Supports rate up to 10.3 Gb/s bit rates
 - ◆ 1G/2G/4G/ 8G/10G Fiber Channel applications.
 - ◆ Cooled EML transmitter and APD receiver
 - ◆ link length up to
-

supply voltage.

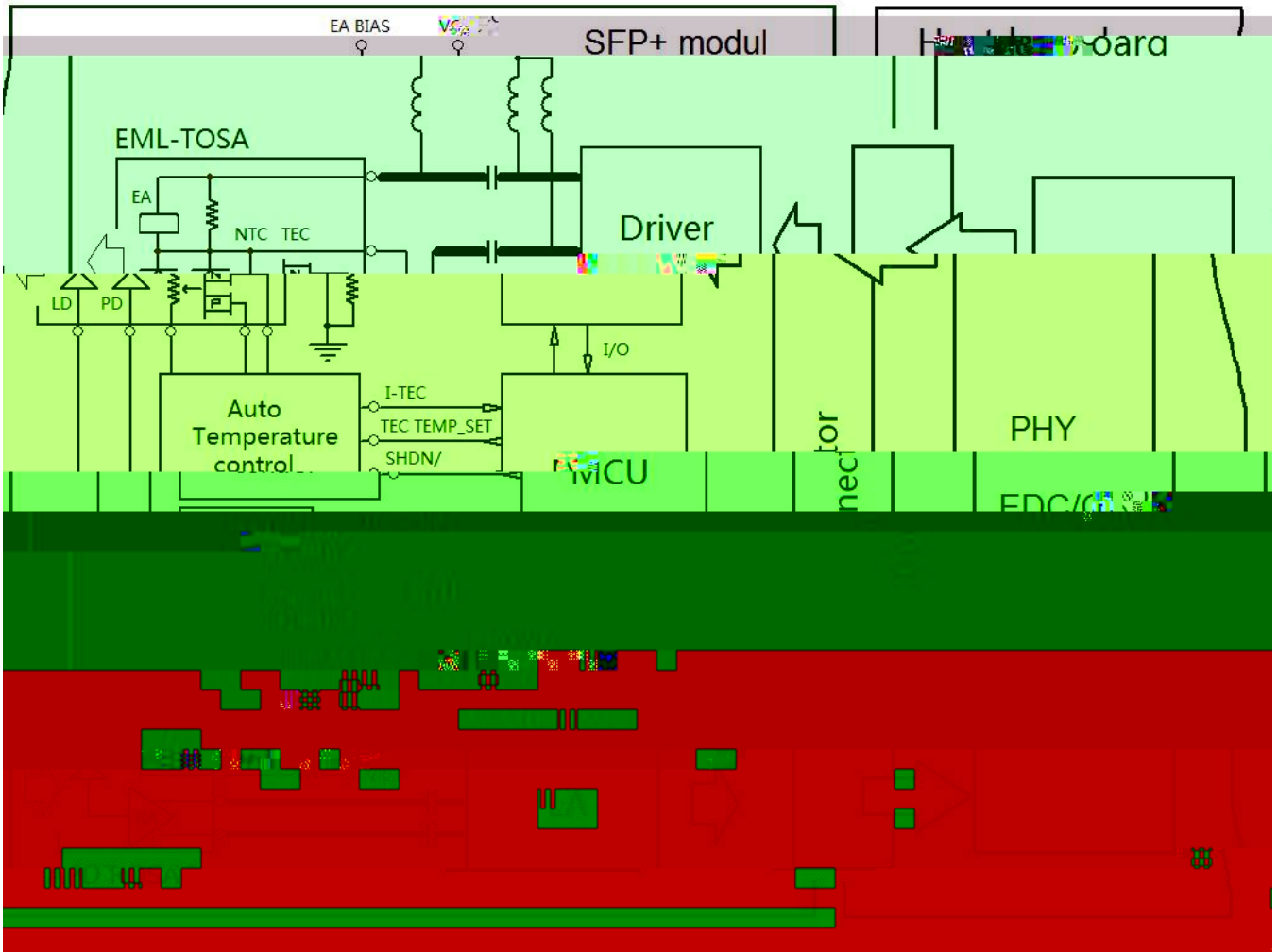

Supply Voltage	Vcc	-0.5	3.8	V
Storage Temperature	Tst	-40	85	°C
Relative Humidity	Rh	0	85	%

Supply Voltage	Vcc	3.13	3.3	3.47	V
Supply current	Icc	-	420	610	mA



Data Rate	Mra	-	10.3	11.3	Gbps
Differential Output Swing	Vout P-P	350	-	850	mV
Rise/Fall Time	Tr / Tf	24	-	-	ps
Loss of Signal –Asserted	VOH	2	-	Vcc3+0.3-	V
Loss of Signal –Negated	VOL	0	-	+0.4	V

Transceiver Temperature	DMI_Temp	-3	+3	degC	Over operating temp
TX Output optical power	DMI_TX	-3	+3	dB	
RX Input optical power	DMI_RX	-3	+3	dB	-3dBm to -12dBm range
Transceiver Supply voltage	DMI_VCC	-0.08	+0.08	V	Full operating range
Bias current monitor	DMI_Ibias	-10%	10%	mA	
Transceiver Temperature	DMI_Temp	-5	70	degC	
TX Output optical power	DMI_TX	-1	+2	dBm	
RX Input optical power	DMI_RX	-26	-7	dBm	
Transceiver Supply voltage	DMI_VCC	3.0	3.6	V	
Bias current monitor	DMI_Ibias	0	100	mA	

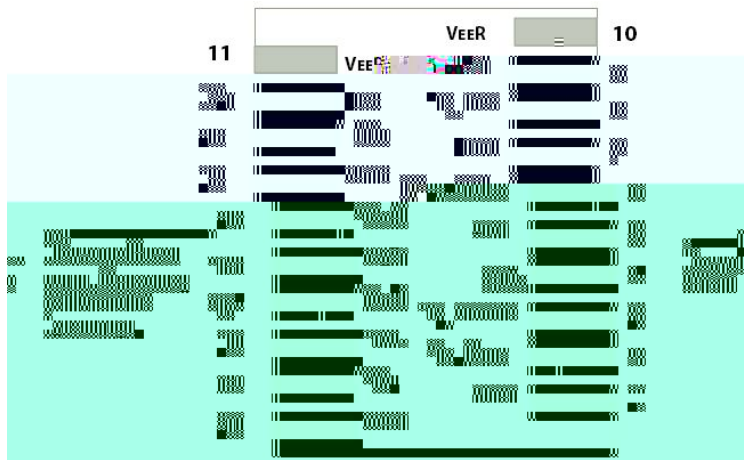



F-tone Networks

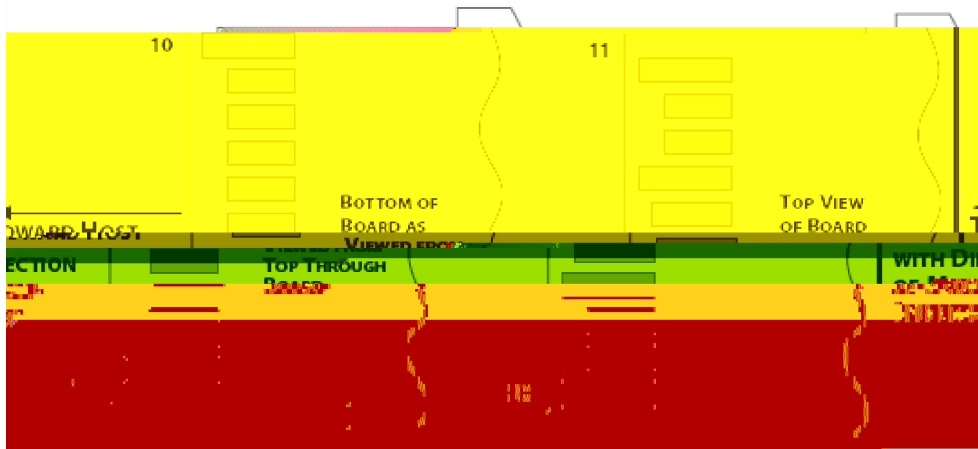



- [1] Module circuit ground is isolated from module chassis ground within the module.
- [2].should be pulled up with 4.7k – 10k ohms on host board to a voltage between 3.15V and 3.6V.
- [3]Tx_Disable is an input contact with a 4.7 k to 10 k pullup to VccT inside the module.
- [4]Mod_ABS is connected to VeeT or VeeR in the SFP+ module. The host may pull this contact up to Vcc_Host with a resistor in the range 4.7 k to 10 k .Mod_ABS is asserted "High" when the SFP+ module is physically absent from a host slot.
- [5] RS0 and RS1 are module inputs and are pulled low to VeeT with > 30 k resistors in the module.

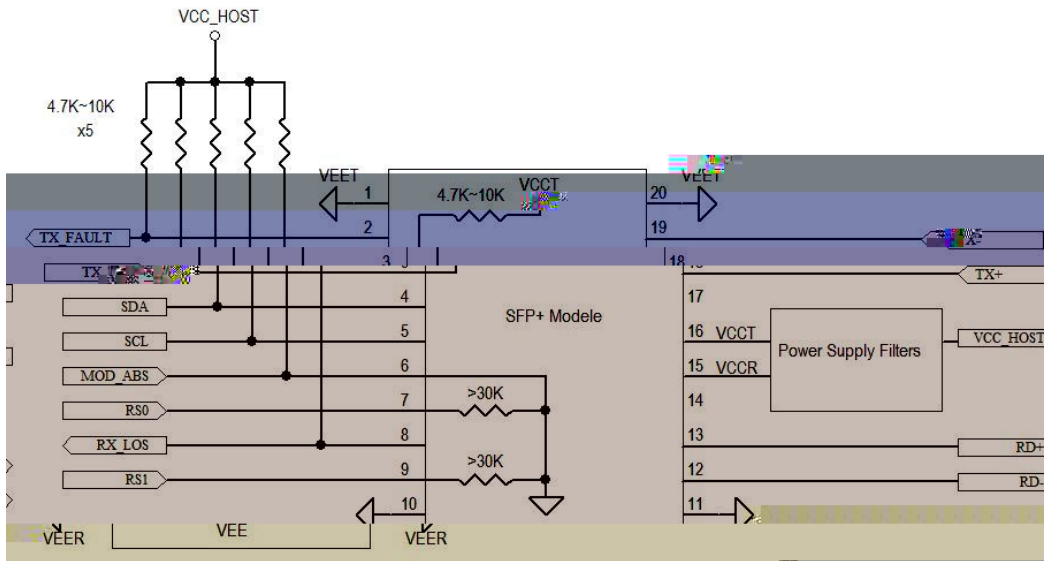
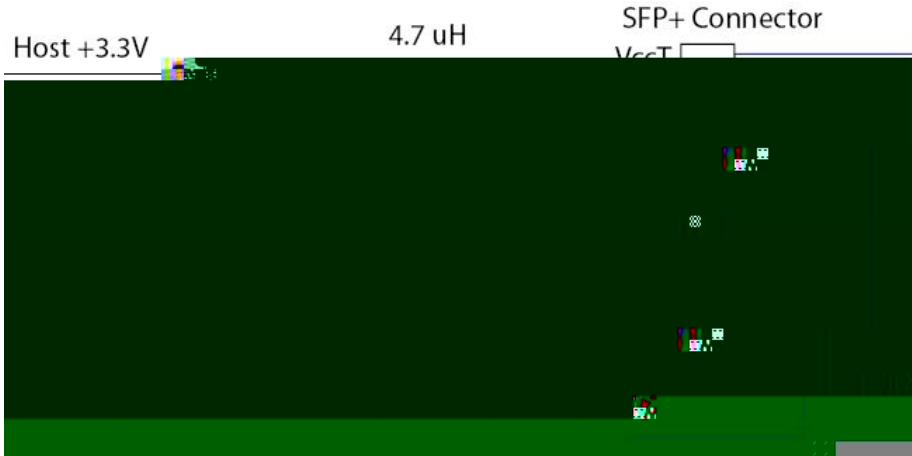

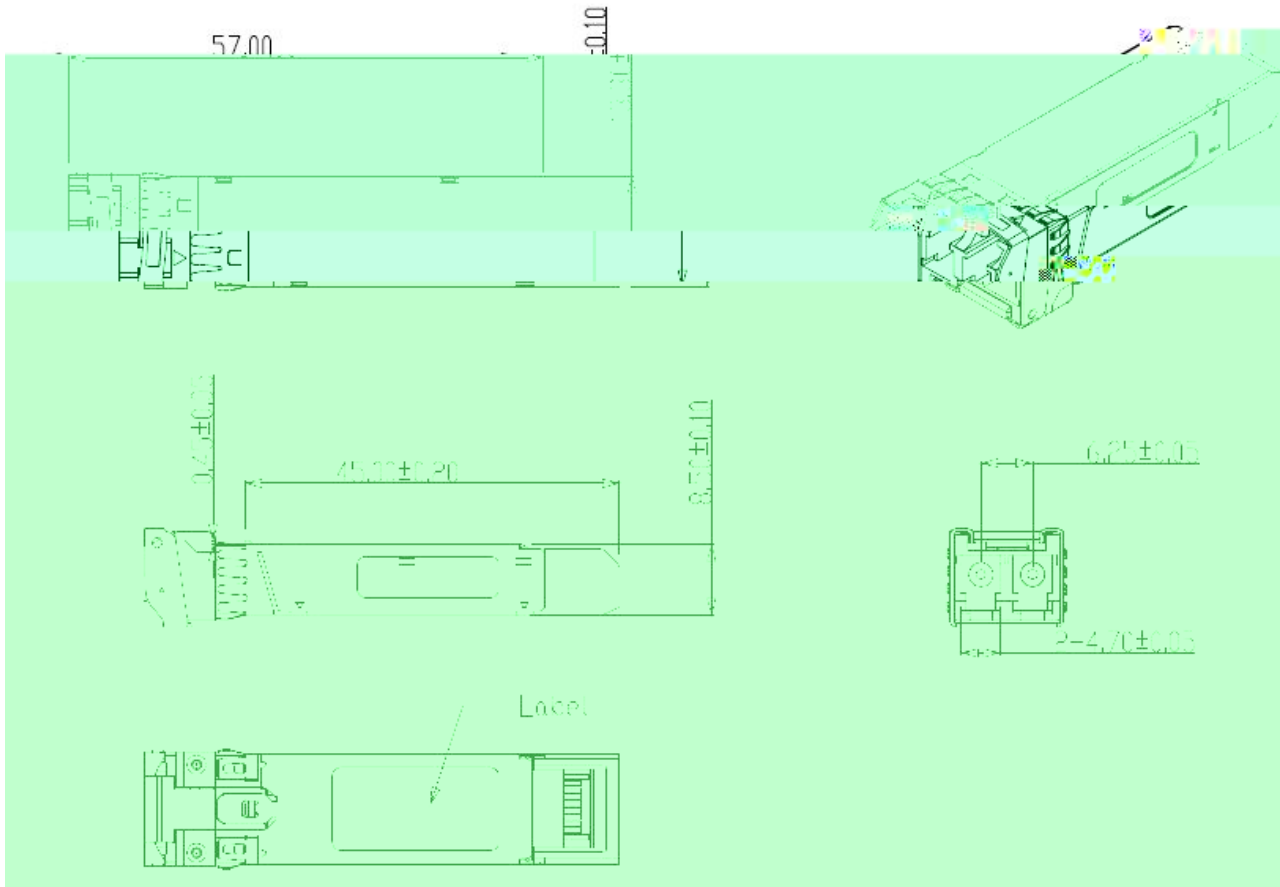

F-tone Networks SFP+ transceiver is designed to be Class I Laser safety compliant and is certified per the following standards:

Laser Safety	FDA	CDRH 21 CFR 1040 and Laser Notice No. 50
Product Safety	UL	UL and CUL EN60950-2:2007
Environmental protection	SGS	RoHS Directive 2002/95/EC
EMC	WALTEK	EN 55022:2006+A1:2007 EN 55024:1998+A1+A2:2003

FTCS-151X-80D	10Gbps, 1550nm SFP+, from 70km to 80km, 0 to +70°C
FTCS-151X-80DI	10Gbps, 1550nm SFP+, from 70km to 80km, -40 to +85°C

1. "Specifications for Enhanced Small Form Factor Pluggable Module SFP+", SFF-8431, Rev 4.1, July 6, 2009.
2. "Improved Pluggable Formfactor", SFF-8432, Rev 4.2, Apr 18, 2007
3. IEEE802.3ae – 2002
4. "Diagnostic Monitoring Interface for Optical Transceivers" SFF-8472, Rev 10.3, Dec 1, 2007

Performance figures, data and any illustrative material provided in this data sheet are typical and must be specifically confirmed in writing by F-tone Networks before they become applicable to any particular order or contract. In accordance with the F-tone Networks policy of continuous improvement specifications may change without notice.

The publication of information in this data sheet does not imply freedom from patent or other protective rights of F-tone Networks or others. Further details are available from any F-tone Networks sales representative.